

**Small locomotive shed
Scale 1:32 Gauge 1**

Entirely made from plywood scraps !

Free manual from Epoca3 <http://www.prouis.it>

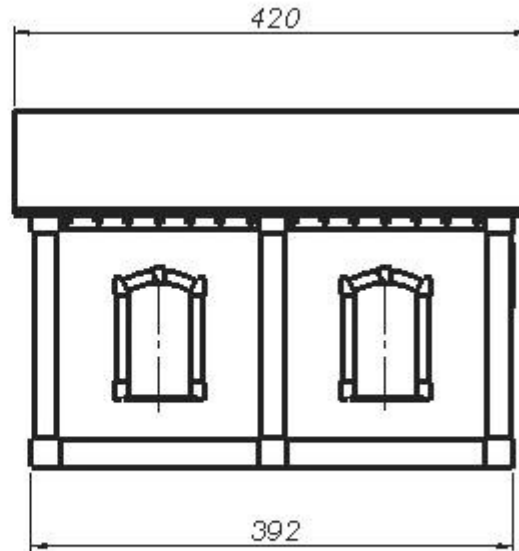
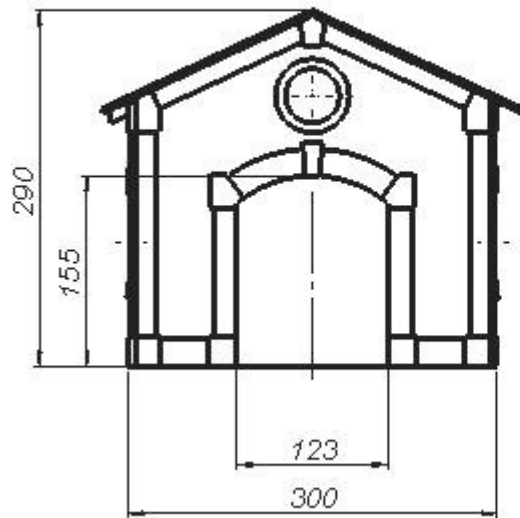
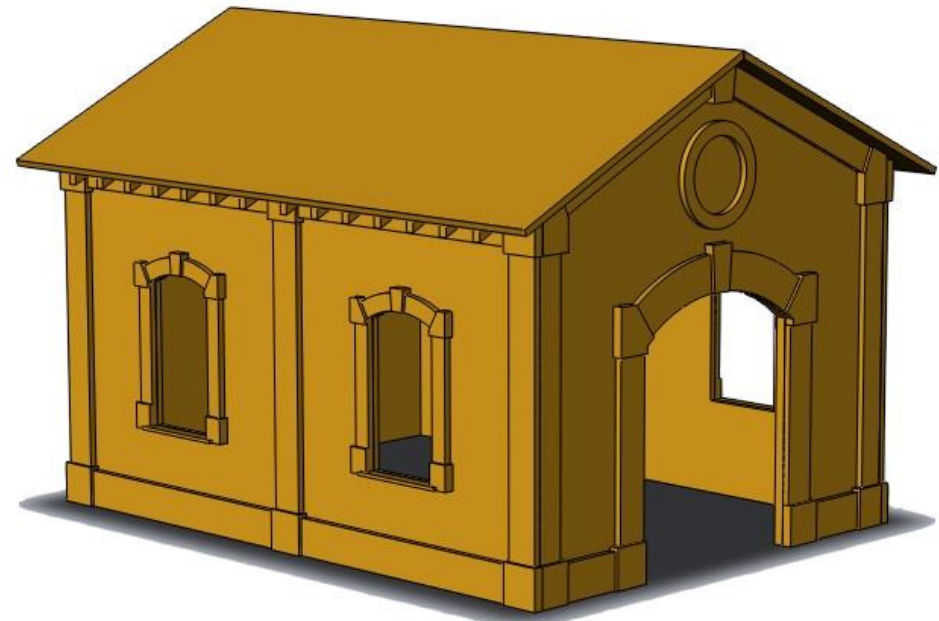

EPOCA3

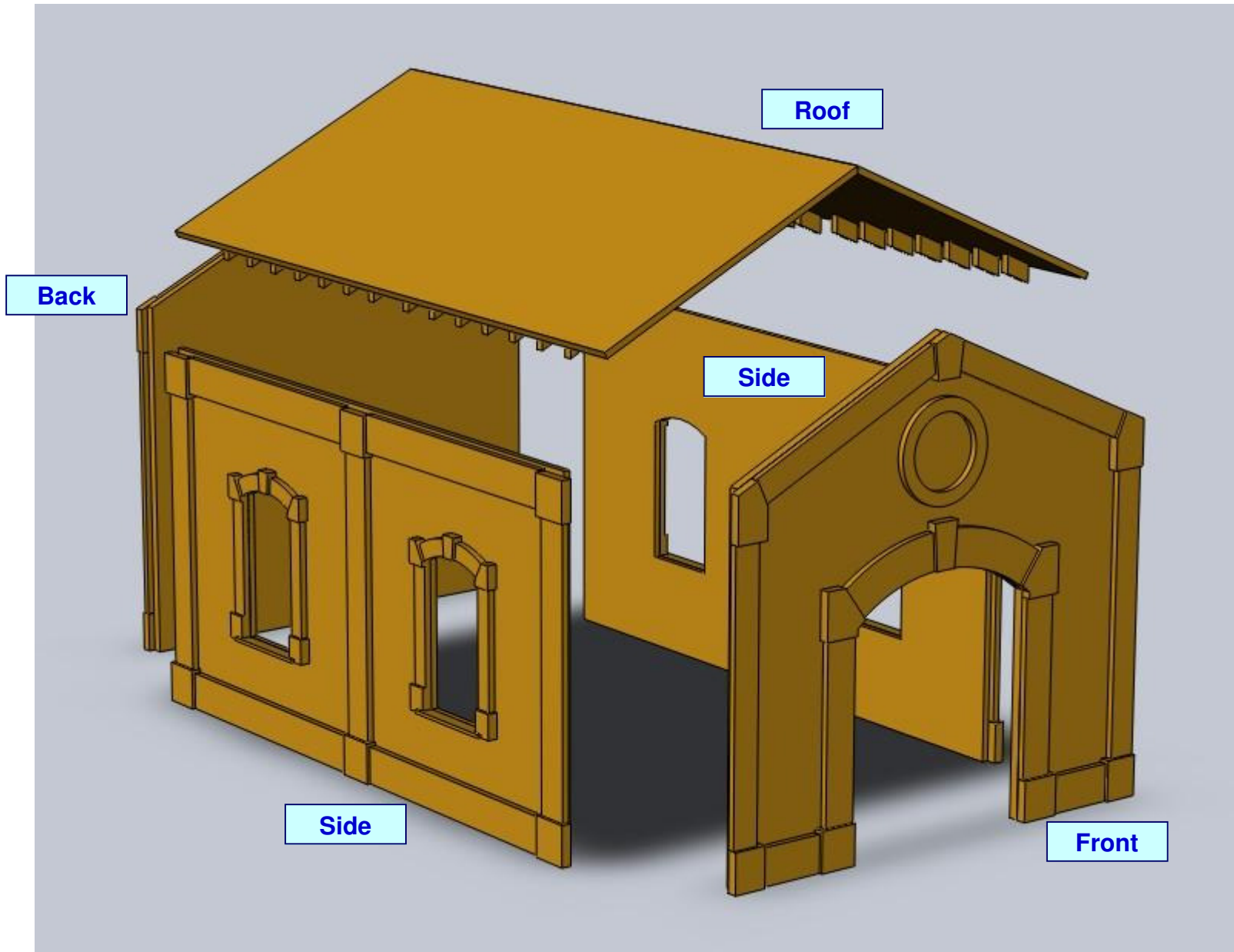

Front assembly

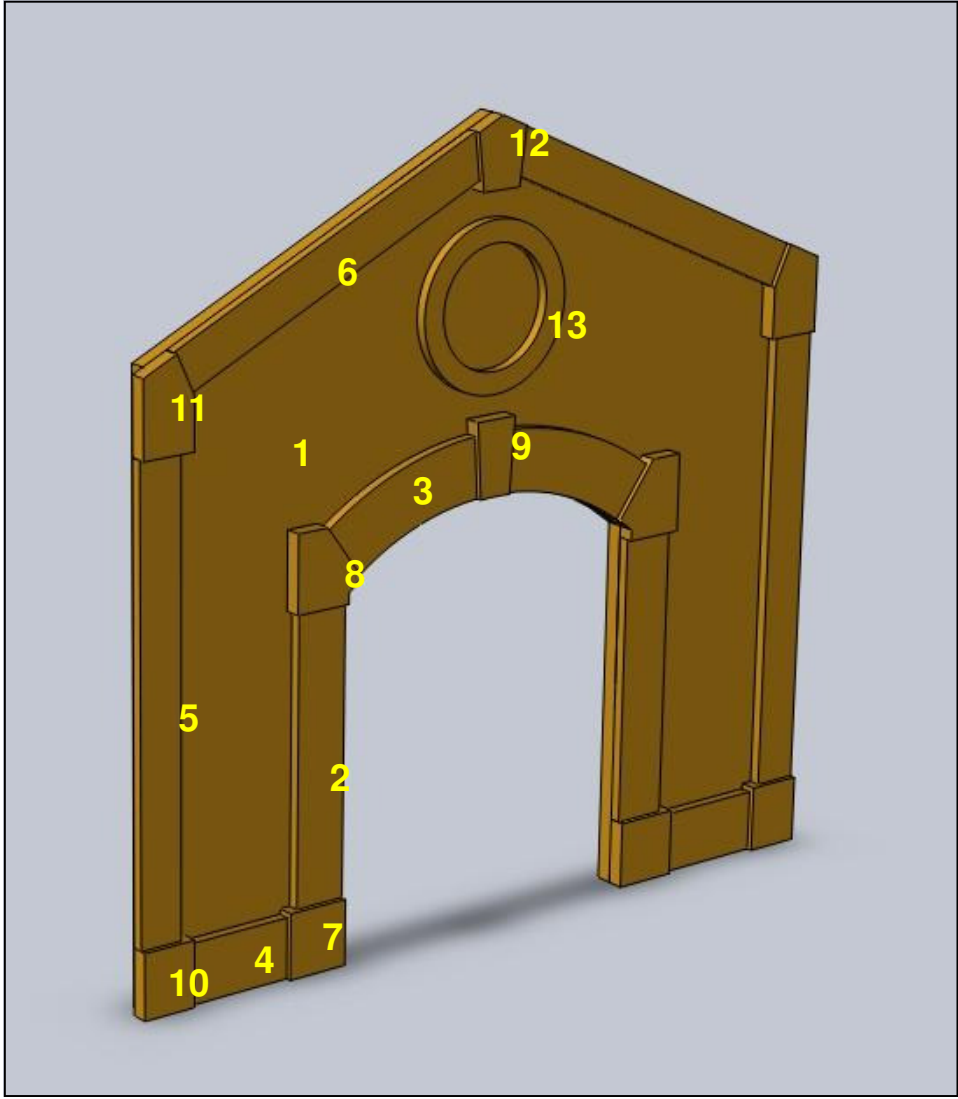
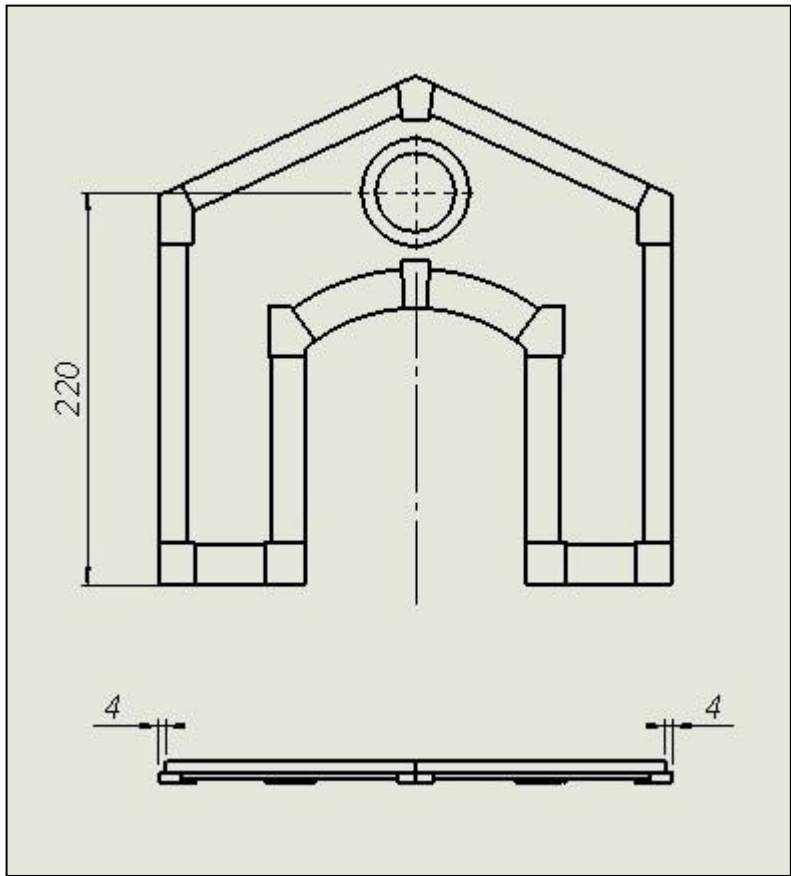

Front details

2

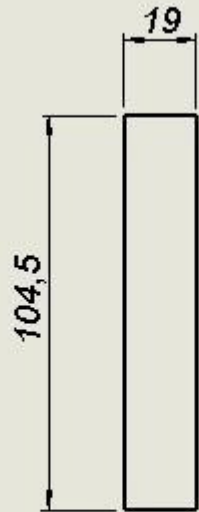

2 off - 4 mm thick

1

1 off - 6 mm thick

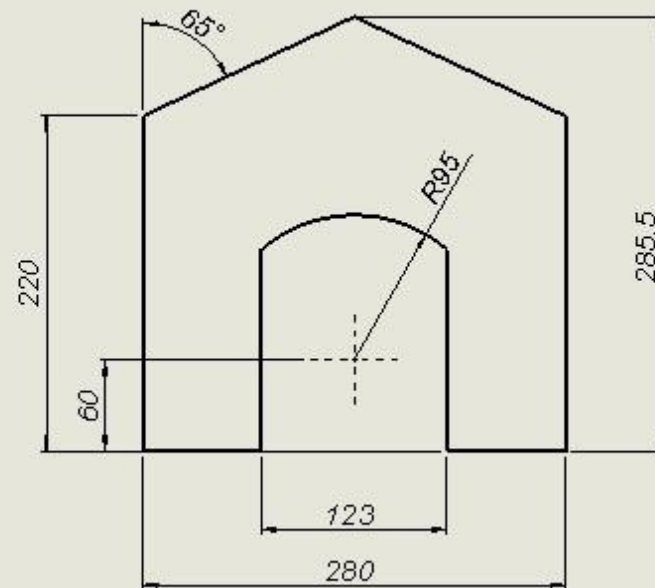

3

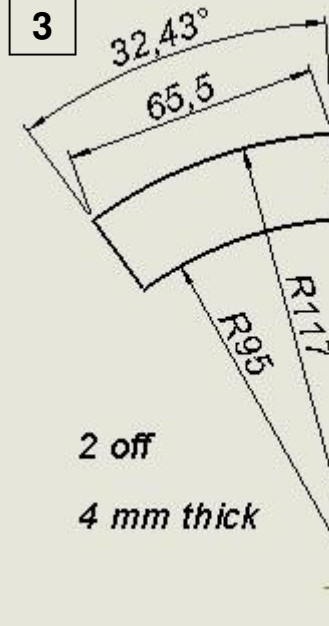

2 off

4 mm thick

4

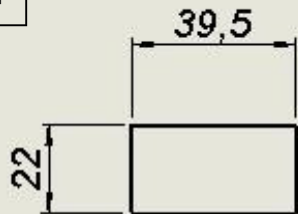

2 off
4 mm thick

5

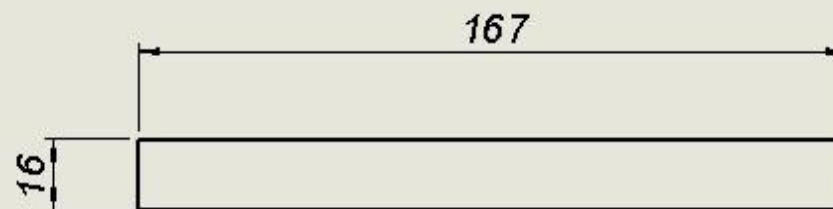

2 off - 4 mm thick

7

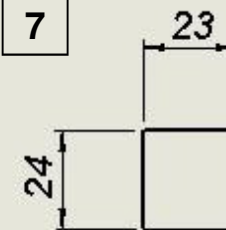

2 off - 6mm thick

Front details

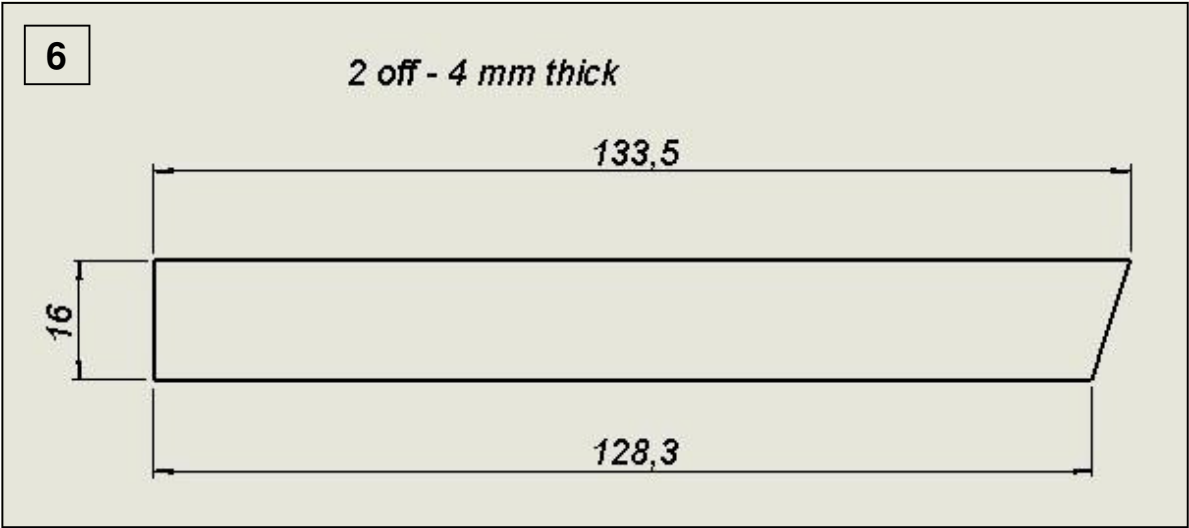
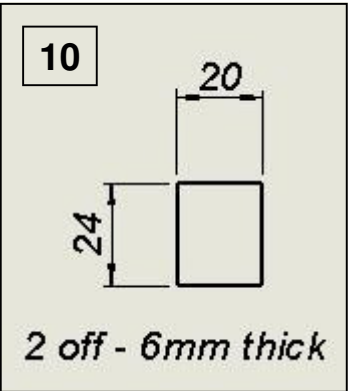
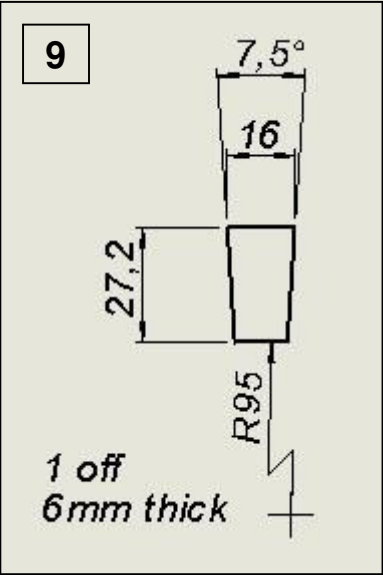
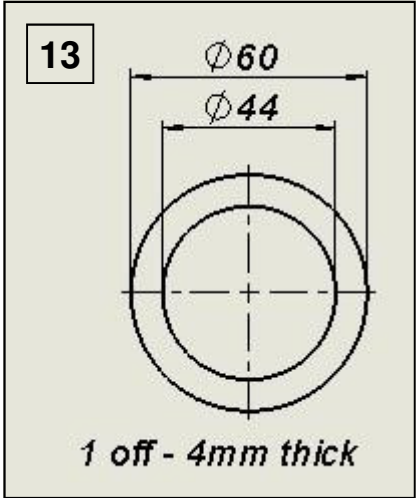
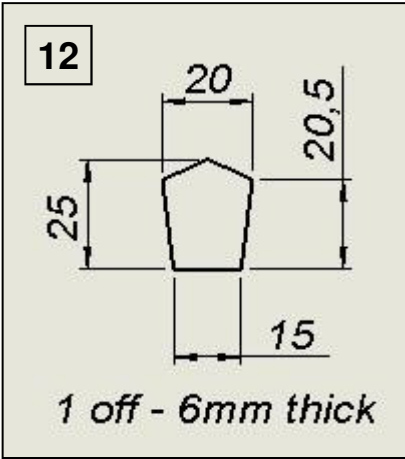
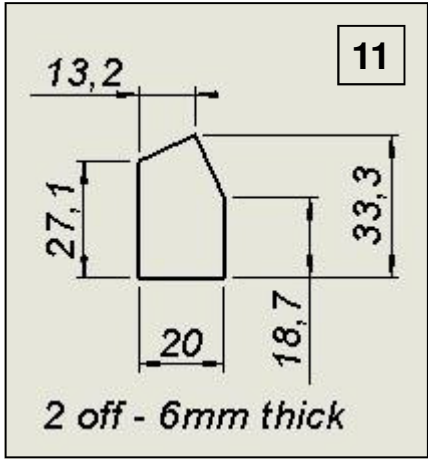
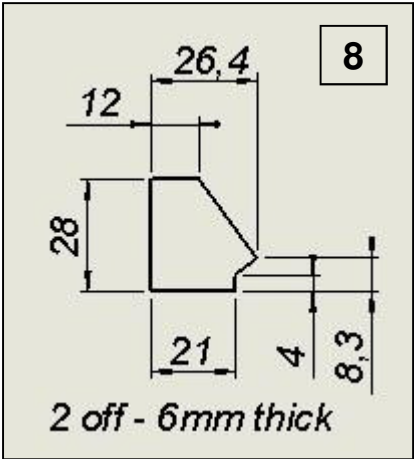

Back assembly

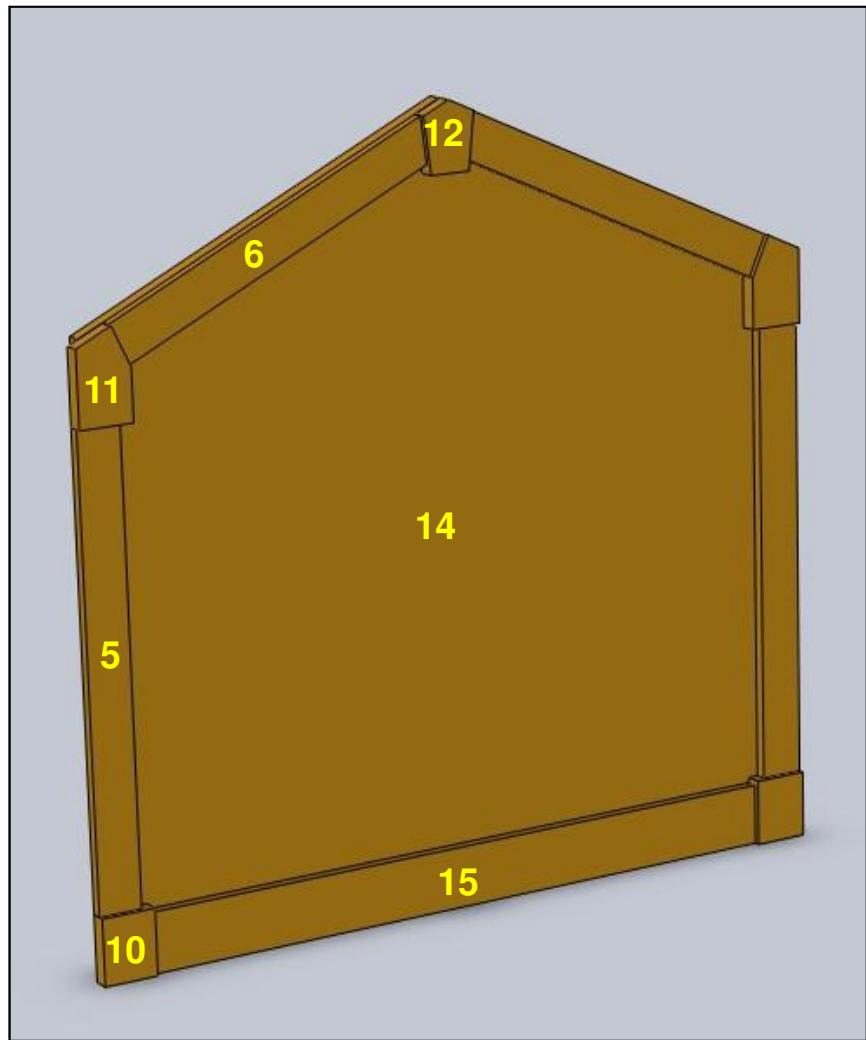
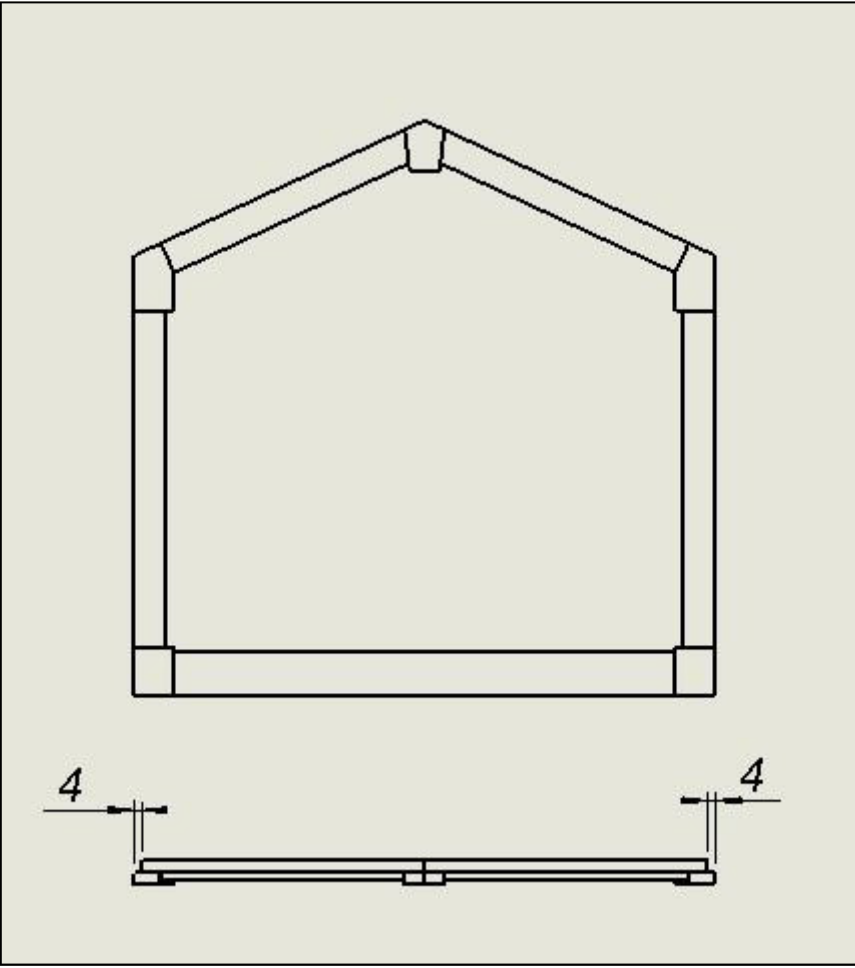

Back details

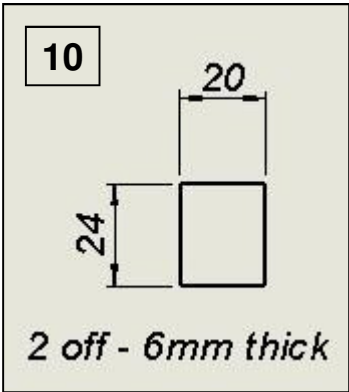
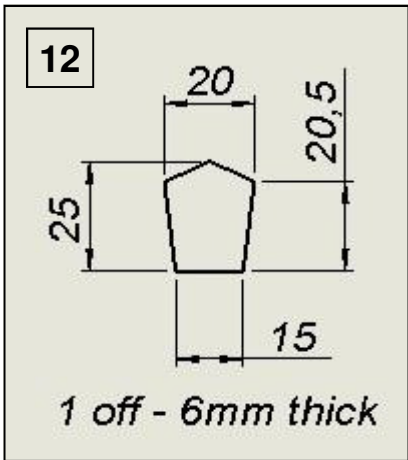
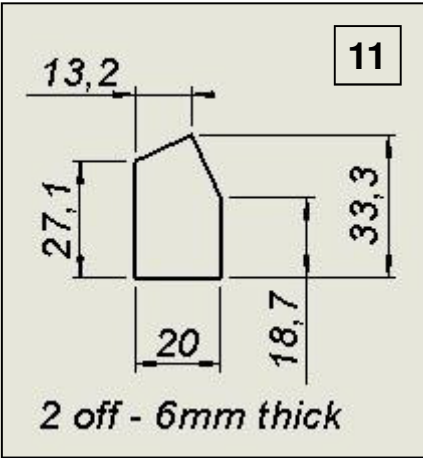
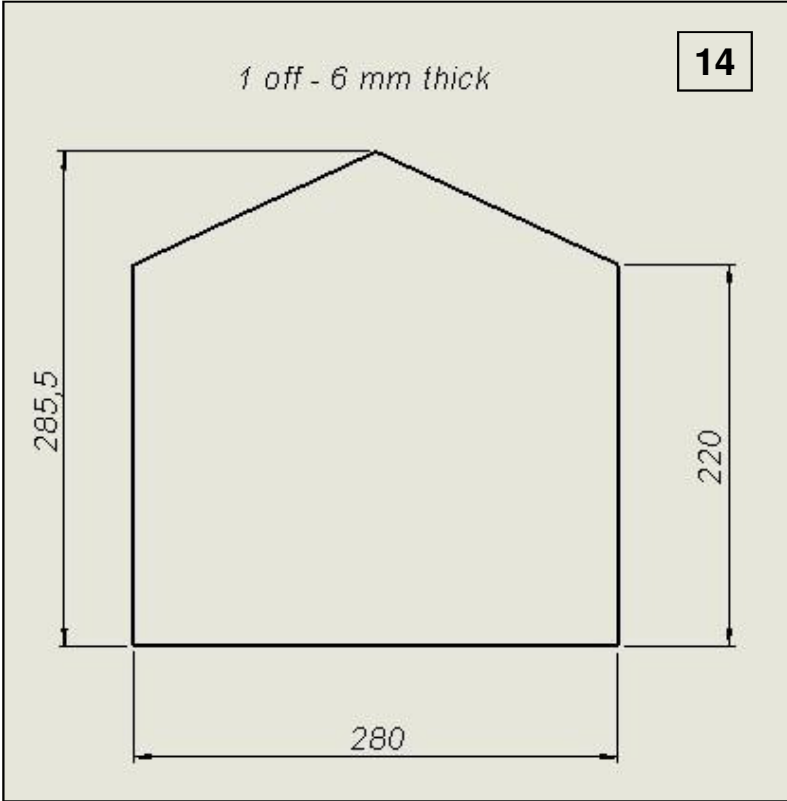
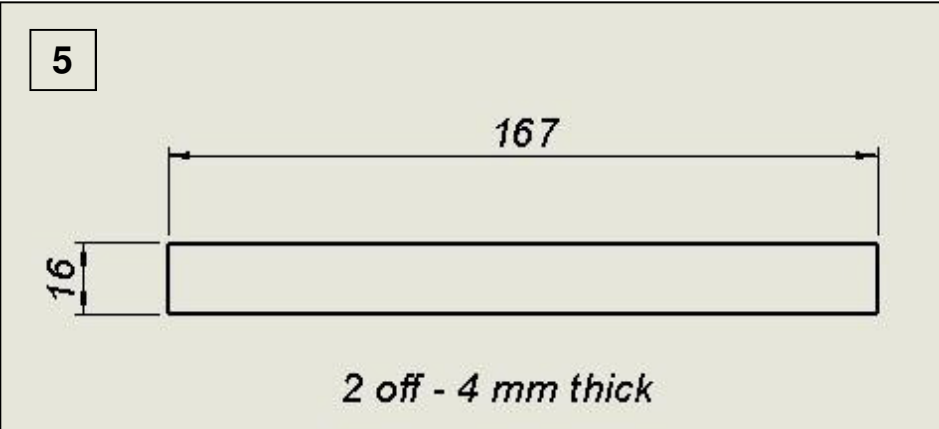

Back details

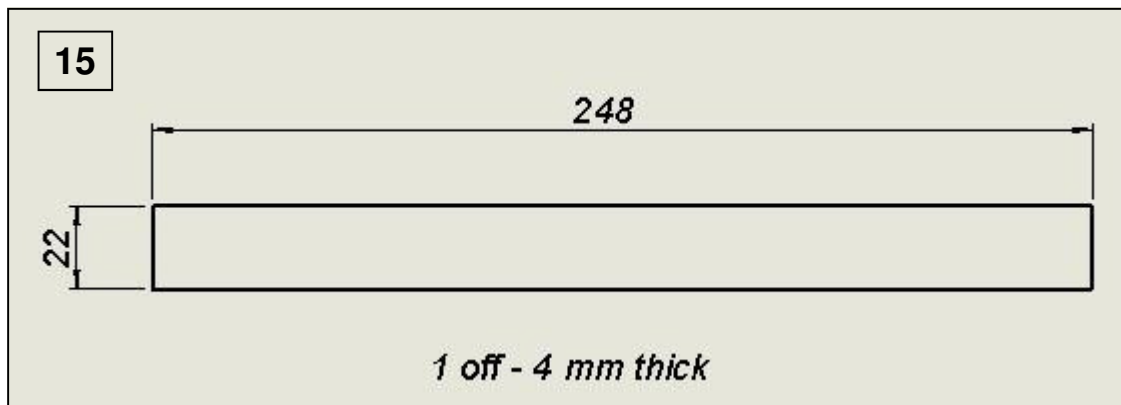
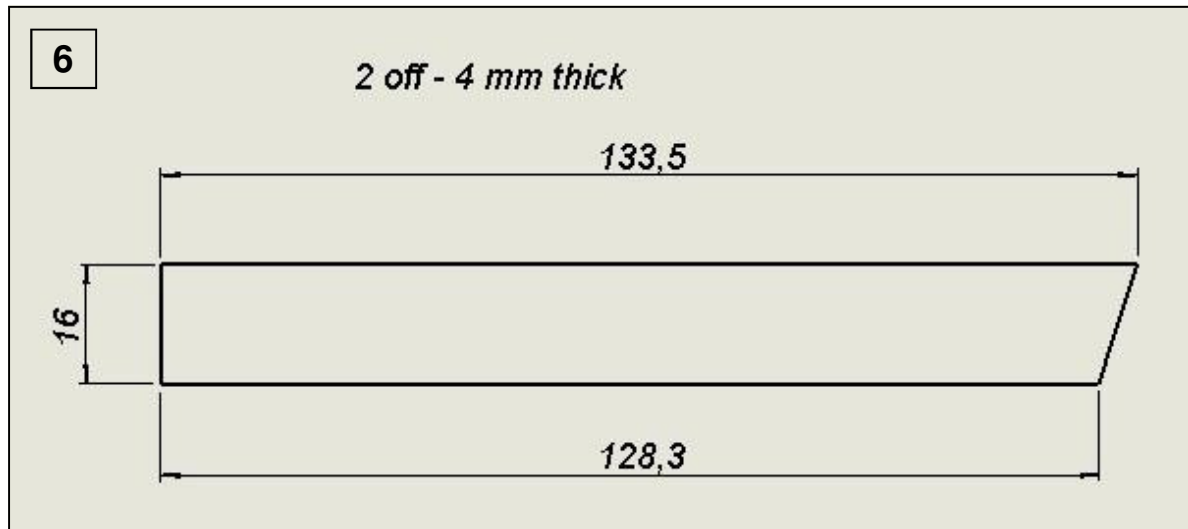

Windows frames

16

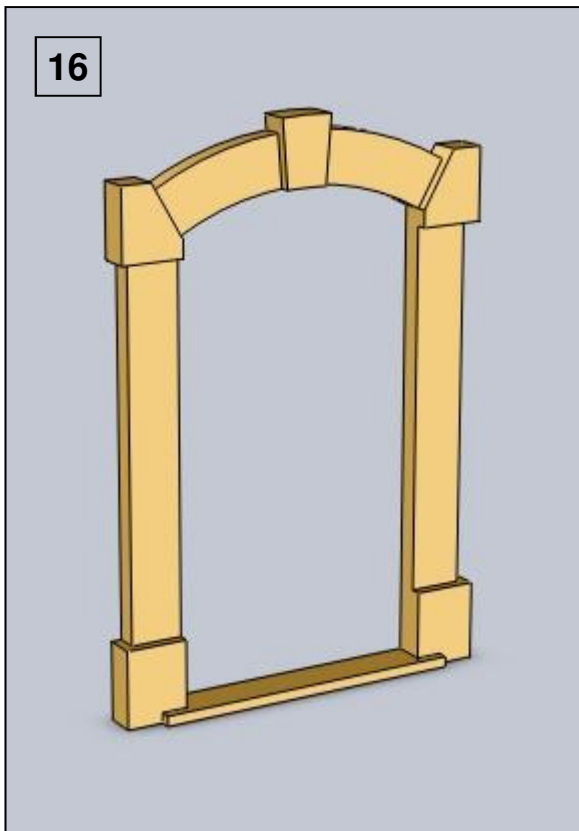

Resin moldings of these windows are available !
Mail me for price and delivery time.
epoca3@prous.it

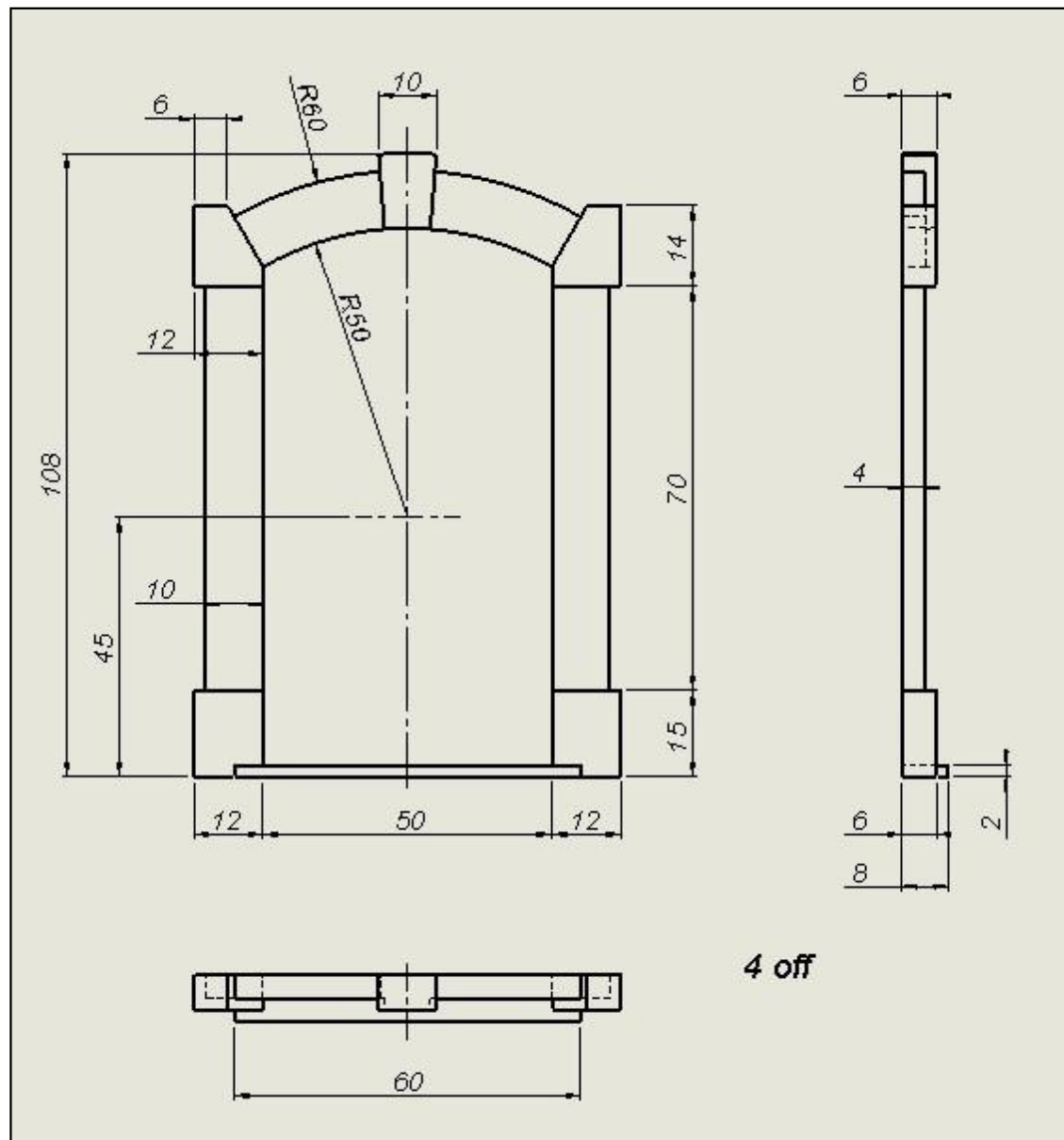

Side assembly - 2 off

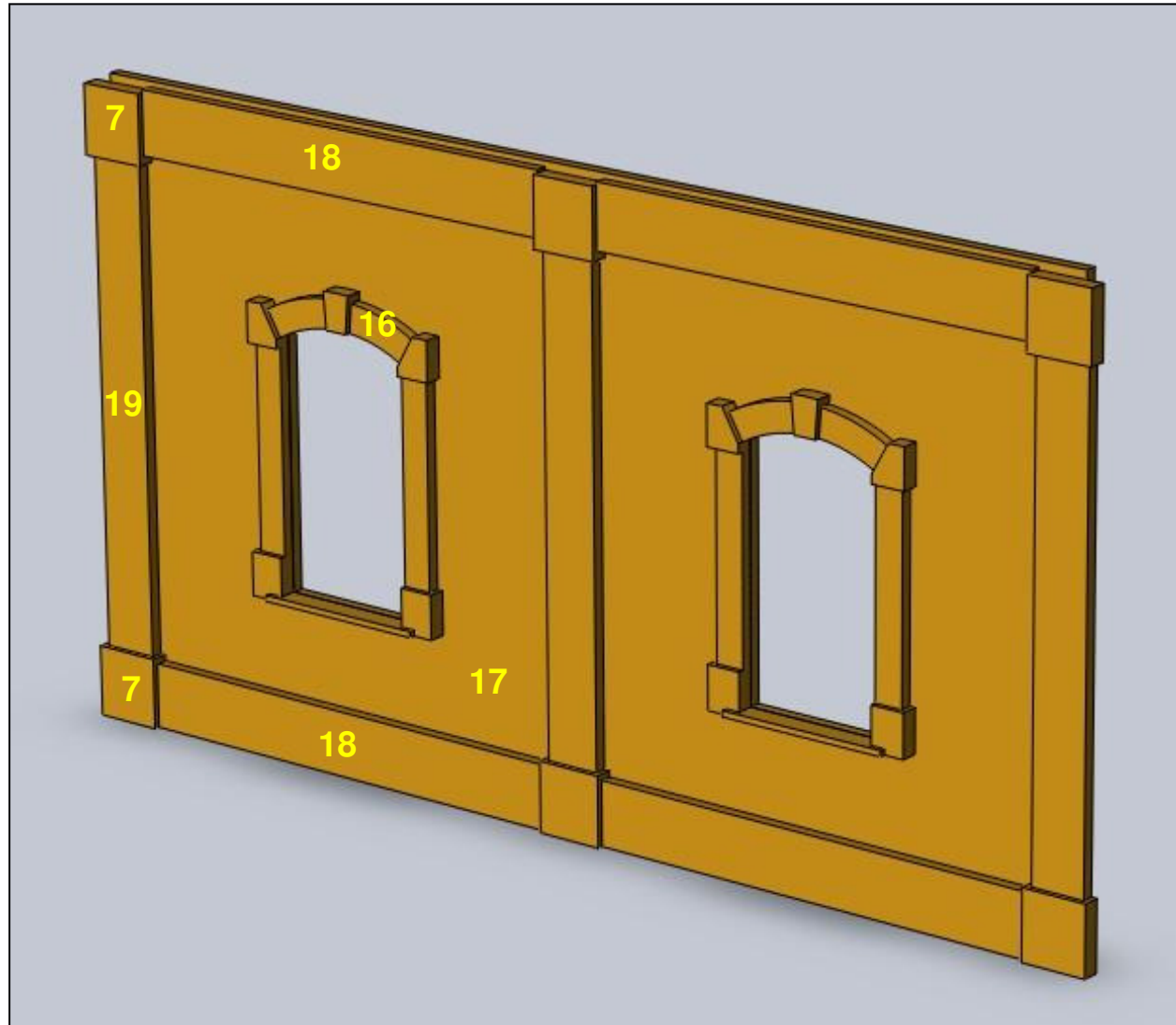

Side assembly

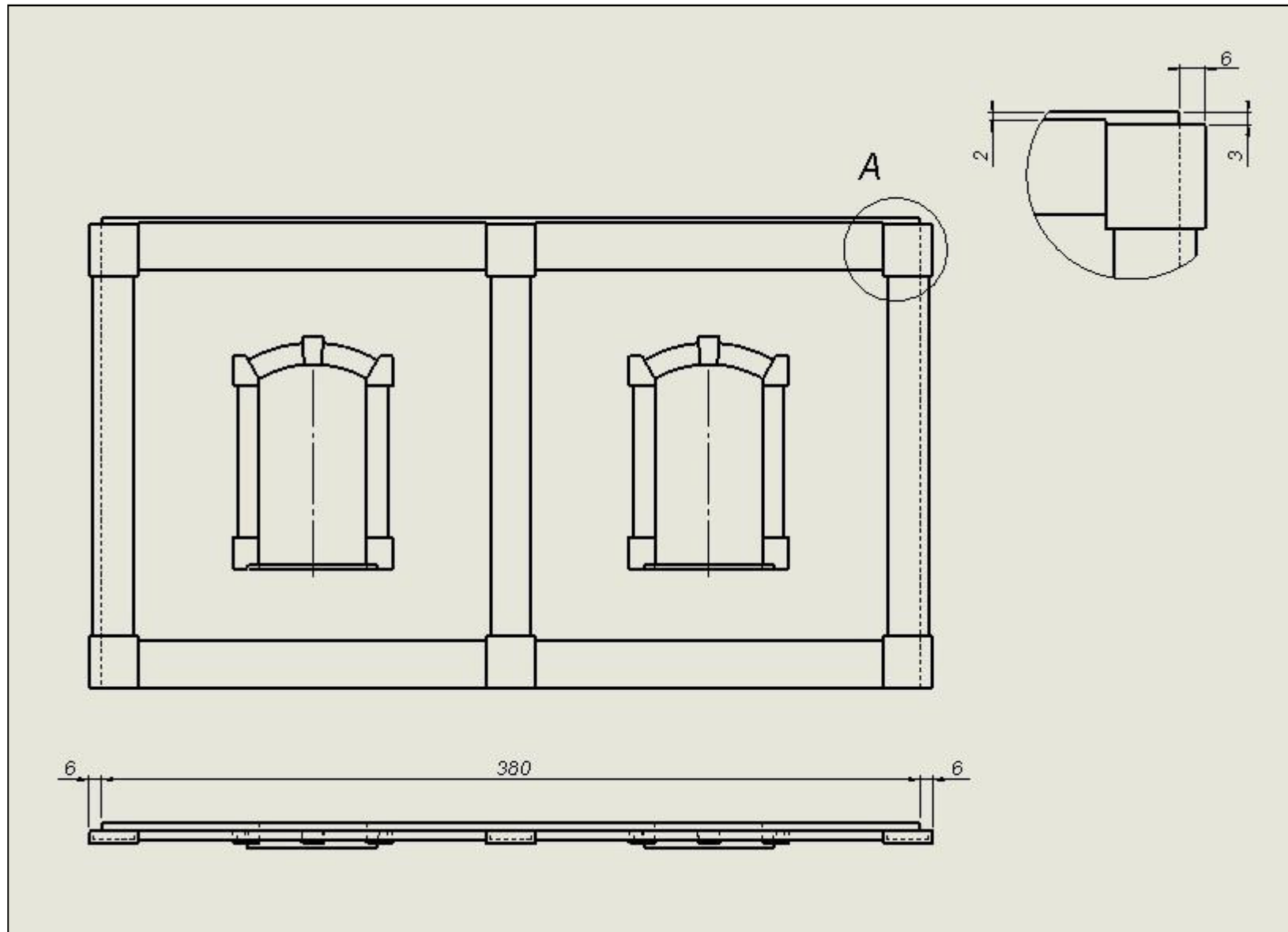

Side details

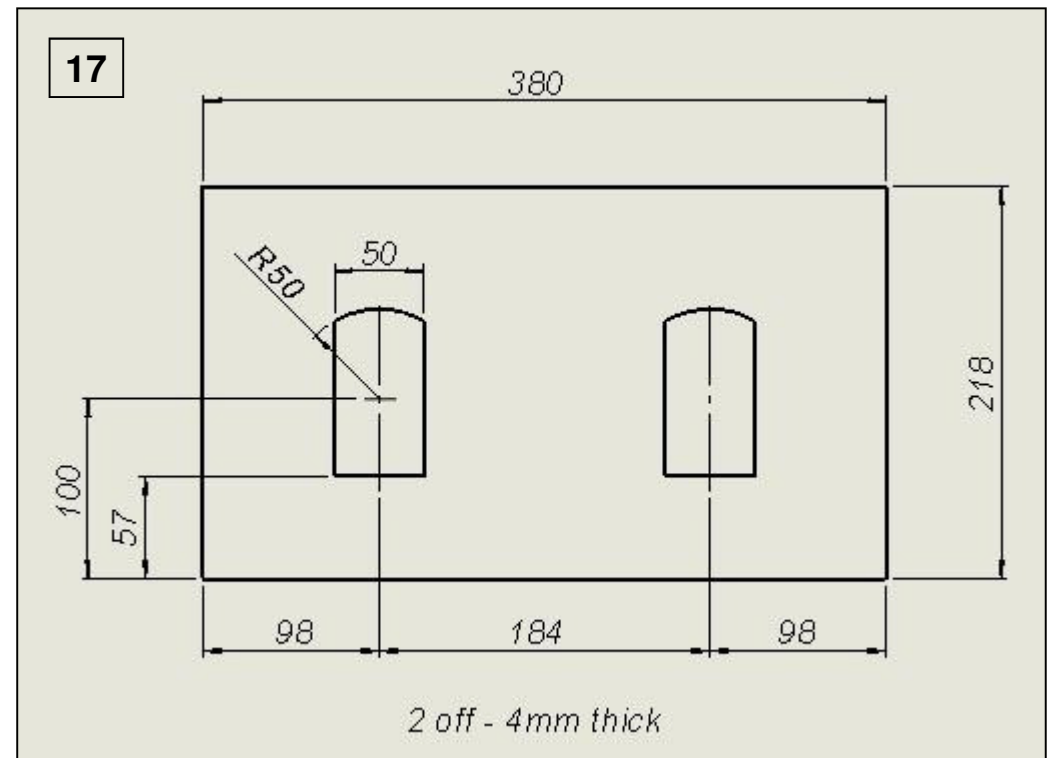
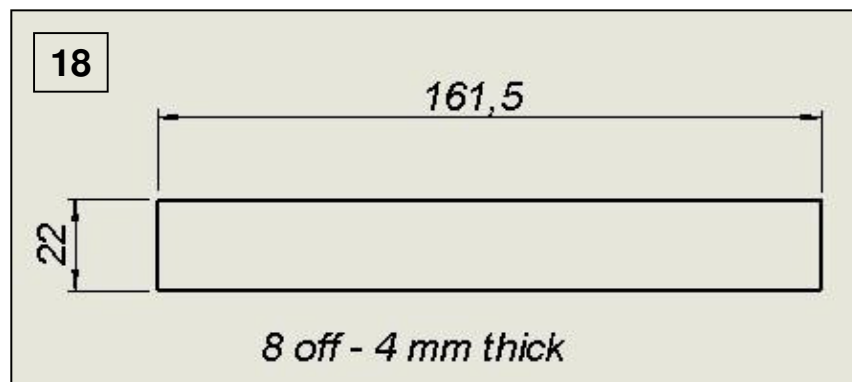
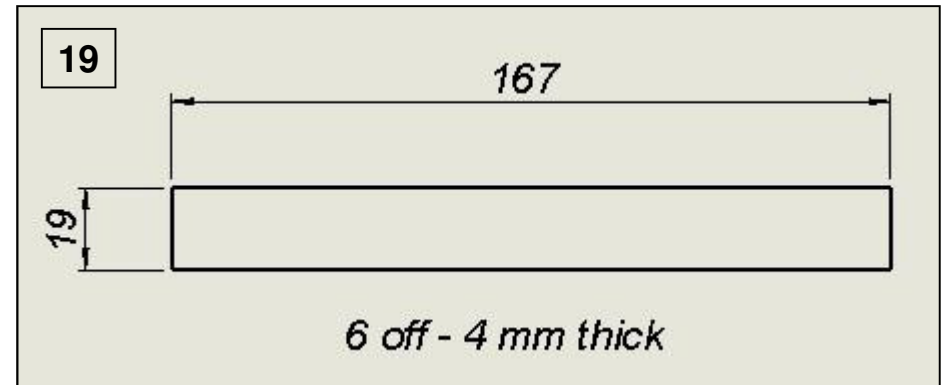
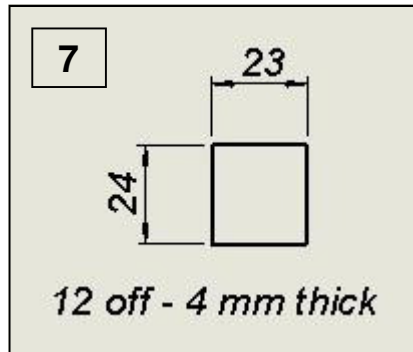

The Roof

